



INSTALLATION AND USER GUIDE

ADVANCE ECO UNVENTED HEAT PUMP AND SOLAR CYLINDERS



ADVANCE APPLIANCES LTD

**PLEASE RETAIN AND ENSURE SERVICE RECORDS
ARE KEPT UP TO DATE**

1. Introduction

The Advance **Eco** unvented heat pump water heater is a high quality stainless steel unvented cylinder providing hot water from a cold mains water supply of between 3 bar and 16 bar. Reduced performance is available at lower pressures although the units are not suitable for pressures lower than 1.5 bar and a flow rate of less than 20 litres per minute. The indirect heat exchange surfaces are designed to provide a rapid heat up time. The unit comes complete with all the necessary safety equipment to comply with legislation governing the installation of such systems. The Advance solar unvented water heater has been designed for use with all solar panels and for heat pump systems a special range is available.

Always register your installation with Advance Appliances - details on www.advanceappliances.co.uk

1.1 Specifiers Guide

The Law & Unvented

It is legal to fit an unvented unit into any property, UK water byelaws were amended to allow this change. There is no longer a requirement to have an old-fashioned 'Tank in the Roof' system.

The Benefits of Unvented

- Annual inspection as per warranty
- Duplex stainless steel
- High quality finish
- Low heat loss for maximum economy
- No sacrificial anode - low maintenance

The Benefits of Unvented Systems

- A real Power Shower without the noisy pump
- No tanks in the roof
- No ball cocks to jam or leak
- All your water, hot and cold, is direct from the mains
- Site the Advance unvented water heater wherever convenient
- The Advance fills your bath in minutes and will run two at the same time (subject to good plumbing and flow rates)
- The Advance can work with electricity, alternative energy systems and conventional gas/oil boilers.

ADVANCE Solar

The Advance solar range is available in heat pump models

Each cylinder has been specifically designed for use with an solar energy heating system and includes a large corrugated coil that provides optimum heat transfer.

The Advance solar unvented water heater should only be used as part of a solar installation and configured as shown.

Additional safety devices may be required if the cylinder is operated with other heat sources.

1.2 Standard Equipment

Before commencing installation check that all the components of your Advance unit are contained in the kit or fitted to the cylinder.

- **3kW Incoloy 825 heating element**
 - incorporating thermostat 70°C and re-settable safety cut-out set at 80°C
- **Cold water control valve**
 - comprising line strainer, check valve & appropriate pressure reducing valve
- **Pressure relief valve**
 - with non-return valve set at 6 bar
- **Tundish**
 - 15mm x 22mm Female x Female
- **Temperature/Pressure relief valve**
 - set at 90°C and 7 bar pressure (factory fitted)
- **Motorised valve** (twin coil heat pump cylinder only)
- **Cylinder thermostat**
 - maximum setting 65°C (factory fitted to indirect units only)
- **Thermal cut-out**
 - set to operate at 87°C+/-3°C
- **Expansion vessel**
 - where required with capacity to suit vessel size

2. Installation Instructions

2.1 Installation



WARNING: UNDER NO CIRCUMSTANCES MUST THE FACTORY FITTED TEMPERATURE PRESSURE RELIEF VALVE BE REMOVED. THIS WILL TOTALLY INVALIDATE ANY GUARANTEE OR CLAIM. THE COLD-WATER INLET VALVE ASSEMBLY MUST BE FITTED OR THE ADVANCE UNIT WILL NOT PERFORM SATISFACTORILY. DO NOT ATTEMPT TO VENT THE PRIMARY CIRCUIT THROUGH THE ADVANCE UNIT. ALL HEAT PUMPS SHOULD BE INSTALLED TO MANUFACTURERS INSTRUCTIONS AND THE PRIMARY CIRCUIT THROUGH THE ADVANCE UNIT MUST BE PUMPED.

Checklist

Please ensure that the installer has fully completed the Checklist on the inside back pages of the installation instructions supplied with the product and that you have signed it to say that you have received a full and clear explanation of its operation. The installer is legally required to complete a commissioning checklist as a means of complying with the appropriate Building Regulations (England and Wales)

All installations must be notified to Local Area Building Control either directly or through a Competent Persons Scheme. A Building Regulations Compliance Certificate will then be issued to the customer who should, on receipt, write the Notification Number on the Checklist.

Siting the Advance Unit

The unit can be placed anywhere convenient. Since it is connected directly to the mains water supply it is equally efficient on any floor – ground, first or second. Avoid areas that may be subject to frost. Try to keep pipe runs as short as possible for maximum economy, especially hot water discharge pipes running down from the Advance unit.

The unit can be fitted into a conventional airing cupboard and does not require any additional insulation.

It **MUST** be accessible for maintenance.

ALL ADVANCE UNITS MUST BE STORED VERTICALLY FOR INDOOR USE ONLY.

The water supply to the cylinder should be potable water direct from a public mains supply with any water treatment equipment functioning correctly.

Storage & Handling

If the cylinder is not being installed immediately, it should remain in its carton with all pipe end protective caps in place to prevent damage.

Connecting the Water Supply

- Pipework is not supplied.
- All pipework should be installed using good plumbing practice & we recommend 22mm mains cold water supply is used.
- Install a Stop Cock Valve before the cold water inlet assembly on the incoming mains water supply so the unit can be isolated if required.

Cold Water Valve

The combined cold water valve (supplied) can be connected anywhere on the cold water mains prior to the unit. It can be located at a point near to where the mains supply enters the premises if this is more convenient. When installing the cold water valve, ensure that the arrow is pointing in the same direction as the mains water supply flow when connecting (see fig 8 and 9).

The cold water balancing port, on the valve, allows you to connect the cold water mains to the rest of the property thus giving balanced pressure throughout. If this facility is not required leave the cap on.

Check Water Pressure & Flow Rates

Advance suggest 15 bar pressure & 20 litres/minute flow rate to be the

minimum requirements for satisfactory operation. Below this the unit will still operate but you will not be able to run two, or more, outlets at the same time. 85% of all UK homes have more than 2 bar pressure.

The mains supply must not exceed 16 bar. If it does a special pressure-reducing valve will be required.

Consideration should be given to the routing of the discharge pipe and the location of the solar panel or alternative energy source.

Drain Tap

A drain tap to drain the unit must be fitted to the cold-water inlet pipe between the Advance unit and the cold water valve assembly at its lowest level possible (see fig 8 and 9).

Pipeworks to Taps

Ideally a 22mm pipe run should supply the outlets throughout the property with short lengths (max 1 metre) runs of 15mm going to baths, showers, and basin taps. Smaller bore pipe can be used to suit taps.

Taps & Fittings

All taps and fittings incorporated into the unvented system should have a rated operating pressure of 7 bar or above.

Inlet Group

The inlet group will vary according to whether the vessel is fitted as internal or external expansion (see fig 7).

2.2 Recommended Installation Schematics

(Fig 6) External Expansion

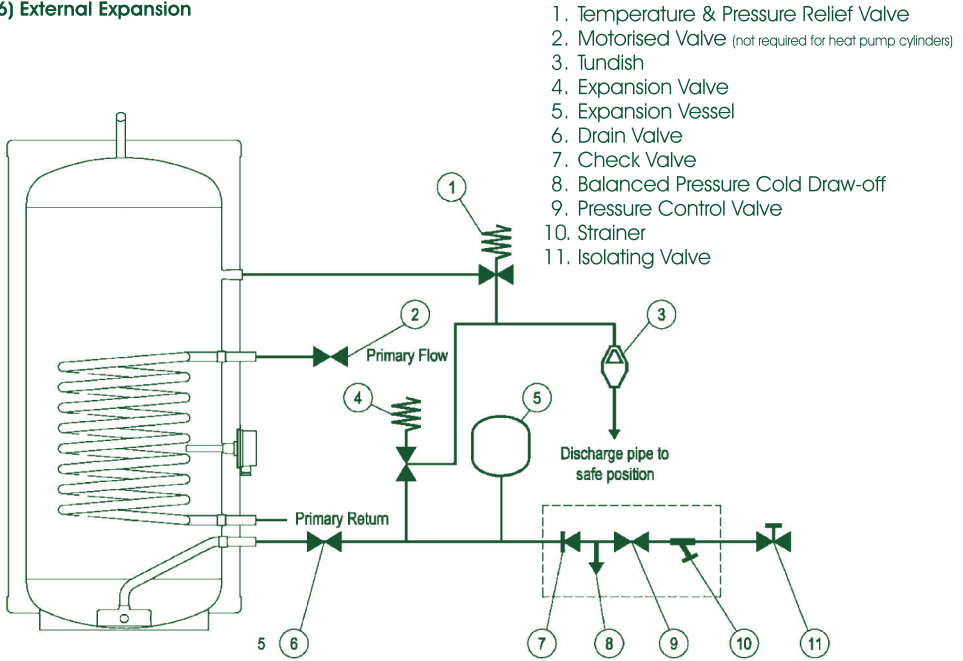

(Fig 7) Inlet Group External Expansion

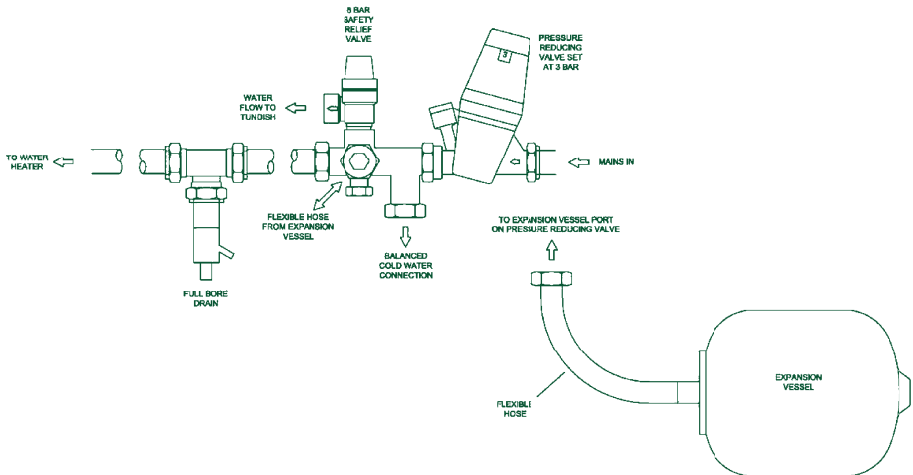

2.3 Wiring Instructions



WARNING: ALL ELECTRICAL WIRING SHOULD BE CARRIED OUT BY A COMPETENT ELECTRICAL CONTRACTOR AND MUST CONFORM TO THE LATEST IEE WIRING REGULATIONS. DO NOT SWITCH THE POWER ON UNTIL THE UNIT HAS BEEN FILLED WITH WATER AND ALL WIRING HAS BEEN EARTHED.

(SEE FIG 8, 9 & 10)



**FOR WIRING ADVANCE ECO CYLINDERS
ALWAYS CONSULT THE HEAT PUMP SUPPLIERS INSTALLATION ADVICE**

Fitting Immersion Heaters

These are supplied as standard 3kW rating. An 'O' ring is supplied as the seal and must be fitted against the flange of the element **Take care not to cross thread and DO NOT use any other type of seal.**

As our heating element is Incoloy 825 and is fitted with a cut-out and thermostat for safety, a non-standard 1 3/4" boss is fitted to the unit. Replacement elements can be obtained from Advance Appliances.

If 6 kW immersion heaters are supplied always use contactors to switch the element as the thermostats are rated at only 3kW.

(Fig. 8)

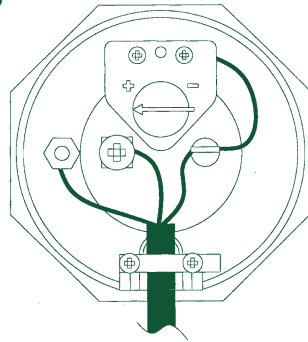

**IMPORTANT. ENSURE THAT THE
IMMERSION HEATER THERMOSTAT
IS SET TO 60°C.**

2.4 Tundish

Tundish

The tundish supplied must be fitted so it is visible to the occupier. The discharge pipe must be 22mm copper pipe. Regulations do not permit more than 3 x 90 - degree bends between the Advance unit and the outflow. Between the temperature & pressure relief valve and the first 90-degree bend there must be a fall of at least 300mm. The fall of the pipework must be continuous and the pipe should terminate in the gully or be bent backwards onto an outside wall, in a place where discharge cannot be injurious to persons.

If you need to site the Advance unit in the middle of the house your discharge pipe to the tundish can be as far away as 9m, which in most cases is enough to run the final discharge point. After 9m, increase the pipe size to a greater diameter than 22mm and accordingly for subsequent 9m lengths, (Table 1).

External Expansion Vessel

This smaller tank is connected to the cold-water inlet side of the vessel. Mount the tank according to separate manufacturers instructions provided with the External Expansion vessel (see Fig 7).

A suitable expansion vessel with a pre-charge pressure of 3.5 bar is supplied with the Advance solar.

The expansion vessel should be Tee'd off between the pressure relief valve and the cylinder (see installation diagram) and should always be positioned with the entry point at the bottom. Installation should always be by means of a standard T connector ensuring no other valve is between this and the cylinder. Adjust the pressure to 3.5 bar.

2.4 Tundish (Continued)

Scale

In hard water areas lower water temperatures can result in less scale being deposited. If a water softener is used it should be capable of flows of approximately 50 lt/min, this will maintain maximum performance of the Advance unit. If no descaler or softener is used then the heating element(s) will need descaling periodically for maximum efficiency and to prevent damage.

(Fig. 9) Tundish Installation

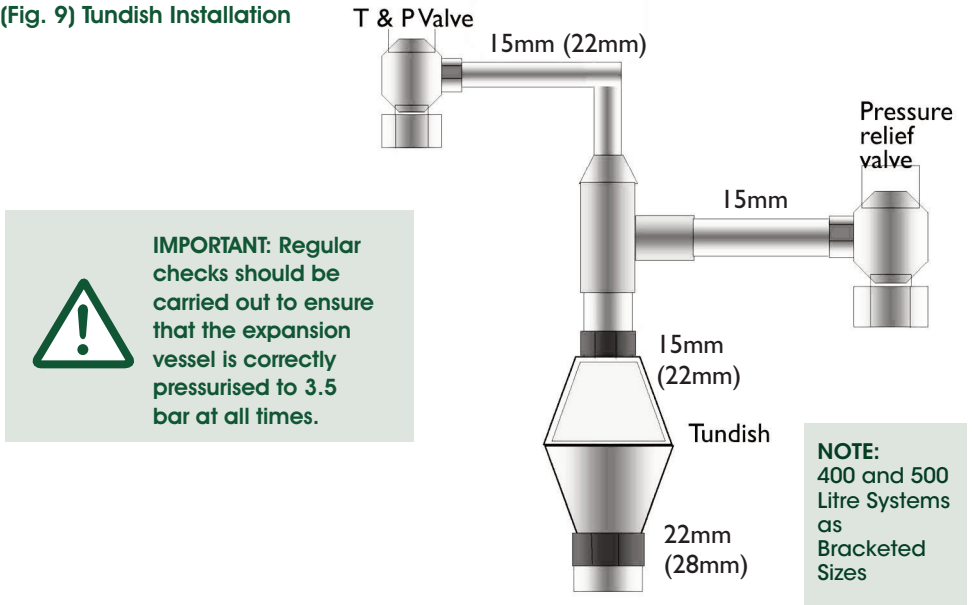

IMPORTANT: Regular checks should be carried out to ensure that the expansion vessel is correctly pressurised to 3.5 bar at all times.

NOTE: 400 and 500 Litre Systems as Bracketed Sizes

2.5 Discharge Pipework

G3 Requirement

'...there shall be precautions to ensure that the hot water discharged from safety devices is safely conveyed to where it is visible but will not cause danger to persons in or about the building.'

G3 Guidance Section 3.5

The discharge pipe (D1) from the vessel up to and including tundish is generally supplied by the manufacturer of the hot water storage system. Where otherwise the installation should include the discharge pipe(s) (D1) from the safety device(s). In either case the tundish should be vertical, located in the same

place as the unvented hot water storage system and be fitted as close as possible to, and lower than, the safety device, with no more than 600mm of pipe between the valve outlet and the tundish.

The discharge pipe (D2)

The discharge pipe (D2) from the tundish should:

- have a vertical section of pipe at least 300mm long below the tundish before any elbows or bends in the pipework (see Fig. 12); and
- be installed with a continuous fall of at least 1 in 200 thereafter.

The discharge pipe (D2) should be made of:

- metal; or
- other material that has been demonstrated to be capable of safely withstanding temperatures of the water discharged and is clearly and permanently marked to identify the product and performance standard (eg. as specified in the relevant part of BS 7291-1:2006 Thermostatic pipes and fittings for hot and cold water for domestic purposes and heating installations in buildings, General Requirements).

2.5 Discharge Pipework (Continued)

Termination of Discharge Pipe Sizing

The discharge pipe (D2) from the tundish should terminate in a safe place where there is no risk to persons in the vicinity of the discharge.

Examples of acceptable discharge arrangements are:

- to a trapped gully with the end of the pipe below a fixed grating and above the water seal;
- downward discharges at low level; i.e. up to 100mm above external surfaces such as car parks, hard standings, grassed areas etc are acceptable providing that a wire cage or similar guard is positioned to prevent contact, whilst maintaining visibility; and,
- discharges at high level: e.g. into a metal hopper and metal downpipe with the end of the discharge pipe clearly visible or onto a roof capable of withstanding high temperature discharges of water and 3m from any plastic guttering system that would collect such discharges.

The discharge would consist of high temperature water and steam roofing felt and non-metallic rainwater goods may be damaged by such. Asphalt, discharges.

Worked Example of Discharge Pipe Sizing

The example below is for a $G_{1/2}$ temperature relief valve with a discharge pipe (D2) having 4 No elbows and length of 7m from the tundish to the point of discharge. From table 1: (overleaf)

Maximum resistance allowed for a straight length of 22mm copper discharge pipe (D2) from $G_{1/2}$ temperature relief valve is 9m. Subtract the resistance for 4 No 22mm elbows at 0.8m each = 3.2m, therefore the permitted length equates to 5.8m. This is less than the actual length of 7m therefore calculate the next largest size

Maximum resistance allowed for a straight length of 28mm pipe (D2) from a $G_{1/2}$ temperature relief valve equates to 18m Subtract the resistance of 4 No 28mm elbows at 1m each = 4m.

Therefore the maximum permitted length equates to 14m As the actual length is 7m a 28mm (D2) copper pipe will be satisfactory.

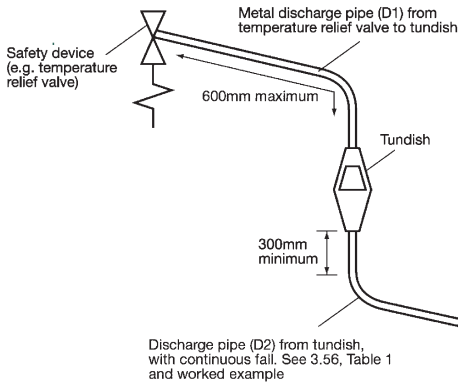

(Fig. 10) Typical discharge pipe arrangement



IMPORTANT: The discharge will consist of scalding water and steam. Asphalt, roofing felt and non-metallic rainwater goods may be damaged by such discharges.

2.5 Discharge Pipework (Continued)

Table 1 Sizing of copper discharge pipe (D2) for common T&P relief valve sizes

Valve Outlet Size	Minimum Size of Discharge Pipe D1	Minimum Size of Discharge Pipe D2	Minimum Resistance Allowed, expressed as a Length of Straight Pipe (i.e no elbows or bends)	Resistance Created by each Elbow or Bend
G1/2	15 mm	22mm	Up to 9m	0.8m
		28mm	Up to 18m	1.0m
		35mm	Up to 27m	1.4m
G3/4	22 mm	28mm	Up to 9m	1.0m
		35mm	Up to 18m	1.4m
		42mm	Up to 27m	1.7m
G1	28 mm	35mm	Up to 9m	1.4m
		42mm	Up to 18m	1.7m
		54mm	Up to 27m	2.3m

2.6 Commissioning

Commissioning a Newly Installed Advance Cylinder

Filling

Check all connections for water tightness including any factory made connections such as the immersion heater and the temperature and pressure relief valve. The pressure in the expansion vessel should be checked to ensure it is 3 bar (45PSI).

The valve is of the car tyre (Schrader) type.

The hot tap furthest away from the Advance Appliances should be opened before filling the system to let air out.

The system should be flushed before use. The remaining taps should be opened in turn to expel air.

2.6 Commissioning (Continued)

Storage Temperature

A storage temperature of 50-55°C is normal for heat pump installations.

Storage at lower temperatures (for example with heat pump cylinders) will require thermal disinfection on a weekly or daily basis - please consult WRAS guide lines.

Safety Checks

Any water coming from either the expansion relief valve or the temperature / pressure relief valve during heat up is indicative of a problem which needs to be identified and rectified. The temperature relief and expansion relief valves should be fully opened, one at a time then both

together allowing as much water as possible to flow through the tundish. Check that your discharge pipework is free from debris and is carrying the water away without spillage over the tundish and release the valves and check that they reseat properly

Electrical Safety

Incorrectly made electrical connections can result in overheating and risk of fire. When installing the product, please ensure the wiring is adequate to minimise risk of overheating. Please ensure you have:

- Used the correct type and cross sectional area cable to meet manufacturer and Wiring Regulation requirements.
- Stripped the insulation from the individual conductors, taking care to not damage the strands of the conductor wire, which would reduce the cross sectional area of the conductor.
- Ensured the conductors are tightly and securely connected to the controls or immersion heater.
- Ensured the bared conductors are correctly inserted into the terminals, to avoid bearing on the insulation sleeve or only partially clamping the conductors.
- Securely anchored the supply cable using the means provided to avoid exerting any external strain to the cable and hence to the terminals
- Checked to ensure the product is earthed correctly; the Live and Neutral connections are to the correct terminals, and the Residual Current Device (RCD) operates correctly.
- As part of the annual service checked the electrical connections to ensure the wires remain in good condition and terminations remain secure. Ensure any spare parts used during maintenance of the product are an authorised spare part and meet the manufacturers' requirement.

The Manufacturers' wiring instructions must always be followed.

2.7 Fault Finding



WARNING: Disconnect electrical supply before removing any electrical equipment cover.

Fault	Possible Cause	Remedy
No hot water	<ol style="list-style-type: none"> 1. Mains supply off 2. Strainer blocked 3. Pressure reducing valve (PRV) fitted the wrong way 	<ol style="list-style-type: none"> 1. Open stopcock 2. Turn water supply off, remove strainer and clean. 3. Re-fit with arrow pointing in direction of flow
Water from hot taps is cold	<ol style="list-style-type: none"> 1. Programmer set to heating only or not switched on for hot water 2. Heat Pump malfunction 3. High limit thermostat has tripped 4. Pump malfunction 	<ol style="list-style-type: none"> 1. Set programmer to call 2. Check heat pump operation if faulty consult your boiler manufacturers instructions 3. Check and re-set 4. Check wiring and/or plumbing connections to pump
Intermittent water discharge through tundish on warm-up	<ol style="list-style-type: none"> 1. Expansion vessel has lost its charge pressure 	<ol style="list-style-type: none"> 1. Turn off stopcock open a hot water tap check vessel charge pressure and recharge to 3.5 bar
Continuous water discharge	<ol style="list-style-type: none"> 1. Pressure reducing valve (PRV) not working 2. Expansion relief valve not seating correctly 3. Temperature and pressure relief valve not seating correctly 	<ol style="list-style-type: none"> 1. Check pressure from PRV if greater than 3.5 bar replace cartridge 2. Manually lift the valve once or twice to clear any debris from the seat otherwise replace valve 3. Manually lift the valve once or twice to clear any debris from the seat otherwise replace valve

Users Instructions

Your Advance unvented hot water duplex stainless cylinder has been designed to give many years of trouble free service and is made from hygienic high grade steel. It includes a 3kW electric immersion heater which can be linked to PV (electric) solar panels for maximum cost running savings,

When a hot tap is turned on there may be a short surge of water, this is quite normal with unvented systems and does not mean there is a fault.

When you first fill a basin the water may sometimes appear milky. This is due to very tiny air bubbles in the water which

will clear very quickly.



WARNING: IF COLD/WARM WATER EXISTS FROM THE TEMPERATURE AND PRESSURE RELIEF VALVE (TPV) OR FROM THE PRESSURE RELIEF VALVE (PRV) CALL YOUR INSTALLER OR THE ADVANCE CUSTOMER SERVICE CENTRE. IF VERY HOT WATER EXISTS FROM EITHER VALVE SWITCH OFF THE HEAT SOURCE IMMEDIATELY AND ISOLATE THE ELECTRICITY SUPPLY TO THE CYLINDER AND SEPARATE HEAT SOURCE.

THE SOLAR SYSTEM IS CONFIGURED TO HEAT THE WATER TO ITS MAXIMUM ECONOMIC TEMPERATURE WHICH MAY VARY WITH OUTSIDE TEMPERATURE AND WEATHER CONDITIONS. THE IMMERSION MAY BE PROGRAMMED TO OPERATE DURING FIXED PERIODS OF THE DAY OR NIGHT.

IF THE HOT WATER RUNS COOL IT MAY BE NECESSARY TO MANUALLY SWITCH ON THE IMMERSION TO HEAT THE WATER – PLEASE SEE THE RELEVANT INSTRUCTIONS FOR YOUR ALTERNATIVE ENERGY DEVICE.

Installation Tips

Secondary Circulation for Heat Pump Cylinders

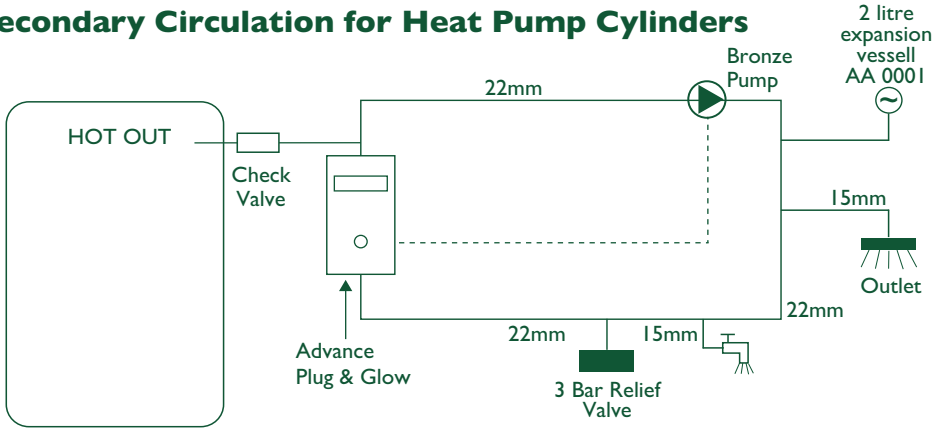

Technical Information

HEAT PUMP CYLINDERS

PRODUCT LINE	ENERGY CLASS	HEAT LOSS IN WATTS	STORAGE VOLUME IN LITRES	SIZE IN MM
ECO HPL 150	A	35	150	580 x 1205
ECO HPL 200	A	44	200	580 x 1545
ECO HPL 250	A	47	250	580 x 1795
ECO HPL 300	A	46	300	580 x 2105
HPL 400	C	93	400	580 x 2050
HPL 500	C	116	500	750 x 1690
ECO HPSL 200	A	44	200	580 x 1545
ECO HPSL 250	A	47	250	580 x 1795
ECO HPSL 300	A	46	300	580 x 2105
HPSL 400	C	93	400	580 x 2050
HPSL 500	C	116	500	750 x 1690

3. Warranty

Advance guarantee the immersion(s) and controls for a period of 1 year from the date of purchase, excluding any failure caused by lime-scale, provided that they have been installed for their intended use by a competent person and have not been modified in any way.

In addition Advance guarantees the stainless steel inner hot water cylinder for a period of 25 years from the date of purchase against faulty material or manufacture provided that:

- a) The vessel has been installed by a competent person in accordance with this manual and all current regulations and codes of practice in place at the time of installation.
- b) It has been used solely for the purpose of heating potable water that complies with current (at the time of installation) EU standards and is not fed with water from a private source.
- c) It had not been modified in any way.
- d) It has not been subjected to excessive pressure or electrolytic action from dissimilar materials, or attack from any salt deposits.
- e) It has been installed indoors in a frost-free environment.
- f) The cylinder is connected to a public water supply maintained by a local water authority.
- g) The unit has been serviced annually
- h) Chlorine water content must be less than 200 ppm.
- i) Water with more than 200 ppm calcium carbonate is treated.

This warranty is not transferable and does not include claims due to frost or lime scale damage.

This guarantee does not cover a procedure of flushing the system not in accordance to the WRAS guidelines pertaining to B.S.6700.

Proof of purchase and annual servicing will be required against any claim. This guarantee does not affect your statutory rights.

4. Servicing & Maintenance

Servicing and maintenance should only be carried out by a competent unvented hot water installer or Advance authorised personnel

Before any work whatsoever is carried out on the installation, it must be isolated from the electricity supply

Both the primary and secondary systems will contain very hot water that will scald, therefore care should be taken when opening any joints, seals or valves

Only use spare parts authorised by Advance The use of other parts will invalidate the warranty

This product should be serviced regularly to optimise its safety, efficiency and performance The service engineer should complete the relevant Service Record on the Checklist after each service. All spare parts can be found on www.advanceappliances.co.uk

5. Annual Service Checks

MAINTAIN THE UNIT ANNUALLY AND CARRY OUT THE FOLLOWING CHECKS, GUARANTEES MAY BE AFFECTED IF THIS ISN'T CARRIED OUT.

1. Expansion Relief Valve- manually open the twist cap and check that the water is discharged and runs clearly through the Tundish and out at the final discharge point. Ensure that the valve re-seats/re-seals itself.
2. Pressure & Temperature Relief Valve- repeat the above procedure. Ensure that the valve reseats/ re-seals itself.
3. Strainer -turn off mains at stopcock. There will be a small amount of residual water in the pipework, remove the cartridge from Pressure Reducing Valve, clean Strainer and replace.
4. Expansion Vessel-check pressure via the valve on top of the vessel which is located under the plastic cap. Ensure pressure is 3 bar. Vessel can be recharged if required- depressurise the system and pump vessel to 3 bar.
5. Check for leaks
6. Check the integrity of all wiring including immersion heater(s). Check earth continuity.
7. Check that the cylinder heating controls do not allow water at the taps above 60°C
8. Keep the service record up to date along with proof of service such as receipts/credit card statements etc.

This does not affect your statutory rights.

SERVICE INTERVAL RECORD

It is recommended that your heating system is serviced regularly and that your service engineer completes the appropriate Service Interval Record below.

SERVICE PROVIDER

Before completing the appropriate Service Interval Record below, please ensure you have carried out the service as described in the manufacturer's instructions and in compliance with all the relevant codes of practice.

SERVICE 1

Engineers Name

Company Name

Tel No.

ID Serial No.

Comments

.....

Signature

SERVICE 2

Engineers Name

Company Name

Tel No.

ID Serial No.

Comments

.....

Signature

SERVICE 3

Engineers Name

Company Name

Tel No.

ID Serial No.

Comments

.....

Signature

SERVICE 4

Engineers Name

Company Name

Tel No.

ID Serial No.

Comments

.....

Signature

SERVICE 5

Engineers Name

Company Name

Tel No.

ID Serial No.

Comments

.....

Signature

SERVICE 6

Engineers Name

Company Name

Tel No.

ID Serial No.

Comments

.....

Signature

WHEN ALL OF THE ABOVE SERVICE HAVE BEEN COMPLETED, PLEASE CONTACT YOUR SERVICE ENGINEER FOR AN ADDITIONAL SERVICE INTERVAL RECORD SHEET.

SERVICE INTERVAL RECORD

It is recommended that your heating system is serviced regularly and that your service engineer completes the appropriate Service Interval Record below.

SERVICE PROVIDER

Before completing the appropriate Service Interval Record below, please ensure you have carried out the service as described in the manufacturer's instructions and in compliance with all the relevant codes of practice.

SERVICE 7

Engineers Name

Company Name

Tel No.

ID Serial No.

Comments

.....

Signature

SERVICE 10

Engineers Name

Company Name

Tel No.

ID Serial No.

Comments

.....

Signature

SERVICE 8

Engineers Name

Company Name

Tel No.

ID Serial No.

Comments

.....

Signature

SERVICE 11

Engineers Name

Company Name

Tel No.

ID Serial No.

Comments

.....

Signature

SERVICE 9

Engineers Name

Company Name

Tel No.

ID Serial No.

Comments

.....

Signature

SERVICE 12

Engineers Name

Company Name

Tel No.

ID Serial No.

Comments

.....

Signature

WHEN ALL OF THE ABOVE SERVICE HAVE BEEN COMPLETED, PLEASE CONTACT YOUR SERVICE ENGINEER FOR AN ADDITIONAL SERVICE INTERVAL RECORD SHEET.

SERVICE INTERVAL RECORD

It is recommended that your heating system is serviced regularly and that your service engineer completes the appropriate Service Interval Record below.

SERVICE PROVIDER

Before completing the appropriate Service Interval Record below, please ensure you have carried out the service as described in the manufacturer's instructions and in compliance with all the relevant codes of practice.

SERVICE 13 Date

Engineers Name

Company Name

Tel No.

ID Serial No.

Comments

Signature

SERVICE 16 Date

Engineers Name

Company Name

Tel No.

ID Serial No.

Comments

Signature

SERVICE 14 Date

Engineers Name

Company Name

Tel No.

ID Serial No.

Comments

Signature

SERVICE 17 Date

Engineers Name

Company Name

Tel No.

ID Serial No.

Comments

Signature

SERVICE 15 Date

Engineers Name

Company Name

Tel No.

ID Serial No.

Comments

Signature

SERVICE 18 Date

Engineers Name

Company Name

Tel No.

ID Serial No.

Comments

Signature

WHEN ALL OF THE ABOVE SERVICE HAVE BEEN COMPLETED, PLEASE CONTACT YOUR SERVICE ENGINEER FOR AN ADDITIONAL SERVICE INTERVAL RECORD SHEET.

INSTALLER & COMMISSIONING ENGINEER DETAILS

CUSTOMER DETAILS

NAME

ADDRESS

TEL No.

INSTALLER DETAILS

NAME

ADDRESS

TEL No.

REGISTRATION DETAILS (Where applicable for unvented systems etc)

REG No.

ID SERIAL No. etc.

COMMISSIONING ENGINEER DETAILS

NAME

ADDRESS

TEL No.

REGISTRATION DETAILS (Where applicable for unvented systems etc)

REG No.

ID SERIAL No. etc.

COMMISSIONING PROCEDURE INFORMATION

CUSTOMER DETAILS

WHAT IS INCOMING COLD WATER PRESSURE ? BAR

HAS STRAINER (IF FITTED) BEEN CLEANED OF INSTALLATION DEBRIS ? Yes No

HAS A WATER TREATMENT DEVICE BEEN FITTED ? Yes No

IF YES TO ABOVE THEN WHAT TYPE ?

UNVENTED SYSTEMS ONLY

ARE T&P AND EXPANSION VALVES FITTED AND DISCHARGE TESTED ? Yes No

IS PRIMARY ENERGY CUT OUT FITTED (NORMALLY 2 PORT VALVE) ? Yes No

WHAT IS OPERATING PRESSURE BAR (PRV SETTINGS) ?

WHERE IS PRV SITUATED ?

HAS STRAINER (IF FITTED) BEEN CLEANED OF INSTALLATION DEBRIS ? Yes No

HAS EXPANSION VESSEL OR INTERNAL AIR GAP BEEN CHECKED ? Yes No

WHAT IS THE CYLINDER THERMOSTAT SETTING ? C

ALL PRODUCTS

HAS THE SYSTEM BEEN EXPLAINED TO THE HOUSEHOLDER? Yes No

HAS THE SYSTEMS LITERATURE BEEN LEFT WITH THE HOUSEHOLDER? Yes No

ENGINEERS SIGNATURE

CUSTOMERS SIGNATURE

APPLIANCE DETAILS / GENERAL INSTALLATION

MANUFACTURER MODEL

CAPACITY (LITRES) SERIAL NO.

HAS THE CHECK BEEN DONE FOR JOINT TIGHTNESS AND LEAKS? Yes No

HAS A CHECK BEEN DONE FOR ELECTRICAL SAFETY? Yes No

ENGINEERS SIGNATURE:



UNIT 4 COPPICE SIDE IND EST BROWNHILLS WALSALL WS8 7EX TEL 01543 377723
For Terms and Conditions go to www.advanceappliances.co.uk