

electric combination boiler ECB 210

Pre wired and pre plumbed electric boiler for mains pressure hot water and vented central heating systems

This electric combination boiler will provide hot water and central heating in one compact unit and comes complete with programmers, pump and immersion heaters ready to plumb straight into your radiator circuit. All hot water controls are fitted too, for a fast and professional installation.

Suitable for all single bathroom electric apartments with four to five radiators

Pre wired and pre plumbed

Self commissioning wet central heating

Mains pressure hot water for fast bath filling and power showering

Safe vented 210 litre store

Danfoss wireless room thermostat/central heating programmer

Timer for off peak electricity

6kw and 3kw immersion heaters fitted

A rated pump fitted and wired

Stainless thermal store
with 10 year guarantee

advance
appliances



The ECB 210 is a plug and play solution for mains hot water and vented heating in the all electric apartment.

The hard work is taken out of the installation as the unit is pre wired and pre plumbed. A few wiring and plumbing connections are all that is required to fit this smart stainless steel unit. It is supplied as shown above.

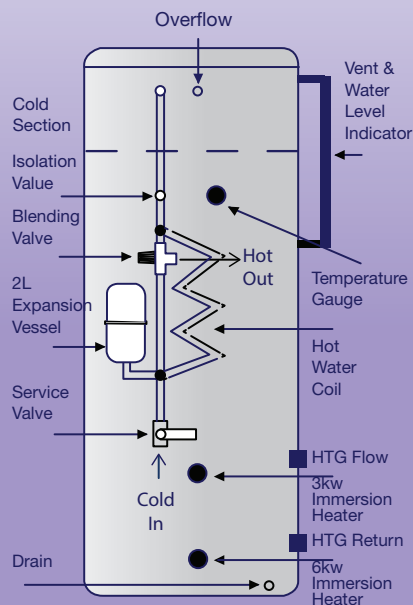

ECB 210 operation

The Advance Electric Combination boiler is perfect for modern all electric apartment dwellers who prefer the comfort of wet central heating systems and mains pressure hot water for powerful showers and quick bath filling.

Two programmers are fitted and wired, one for off peak (usually overnight) electricity tariffs and one for switching the central heating on and off during the day. The central heating programmer/room thermostat is wireless and can be used without the need for additional wiring.

There is sufficient hot water from an overnight charge for a shower and a bath. A second immersion heater is fitted for hot water boost.

The product meets HWA Thermal Store Specification and part G and L of the Building Regulations.

The lower part of the store is dedicated to central heating. A 6kw immersion heater is fitted for this purpose, and can be used in systems up to four or five radiators. During start up periods the energy stored in the lower part of boiler is ready for immediate use. If the water in the radiators falls overnight to 20 °C, for example, the 6kw heater is adequate for demand of up to 10kw when first switched on in the day.

When heating is switched on water is pumped from the store to the radiators and has the benefit of providing immediate heat. Using the off-peak controller, the immersion heater will have heated the store to 75 °C which is the recommended temperature.

A temperature gauge is fitted for convenience and diagnostics.

In the higher part of the tank is a large efficient hot water coil which draws heat from the store for hot outlets in the property. It is connected to the mains so provides fast safe hot water to all outlets without the need for pumps.

Your morning shower will not be compromised if the heating is on.

wiring schematic

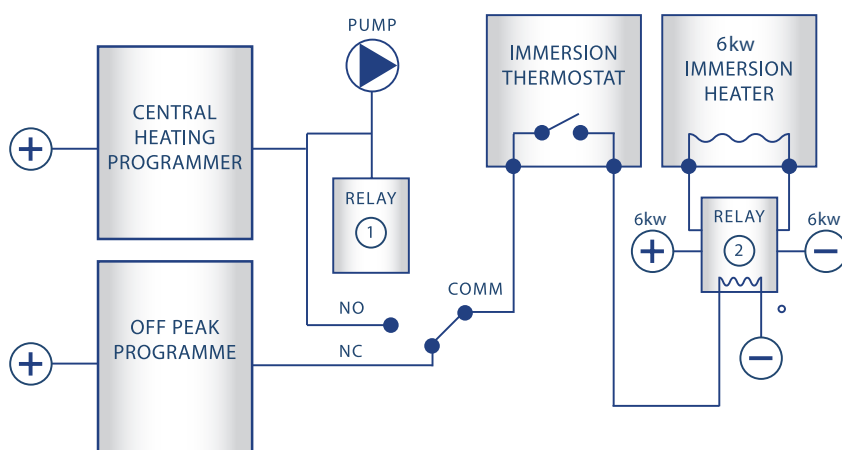

specification

CAPACITY	HEATING RATING	WEIGHT FULL	HGT x DIA	HEAT LOSS
210 HOT 20 COLD	6KW TO 10KW	250KG	1750 x 600	1.92KWHR/24HRS

ECB 210 Installation

The ECB is pre wired. The installer must be a qualified electrician and meet all appropriate current Regulations and Codes of Practice.

A 3 amp supply is to be wired to the main junction box as indicated in the box.

The large contactor must have a 30 amp switched supply connected as directed above.

This supply must be direct from the board in the property.

It must be connected by a suitably qualified electrician and all relevant and current Building Regulations and Codes of Practice must be observed.

the wiring centres



Full instructions are supplied with the unit for the plumbing and wiring. A dedicated 30 amp supply will be required for the 6kw immersion heater supply in addition to a 3 amp supply for the programmers and pump as shown above.



Advance Appliances
Unit 4 Coppice Side Ind Est.
Brownhills, Walsall, West Midlands
WS8 7EX
T: 01543 377723
F: 01543 360620
E: sales@advanceappliances.co.uk