

SERVICE INTERVAL RECORD

Service regularly by an approved engineer and record details below

SERVICE 1

Engineers Name
Company Name
Tel No.
ID Serial No.
Comments
.....
Signature

SERVICE 2

Engineers Name
Company Name
Tel No.
ID Serial No.
Comments
.....
Signature

SERVICE 3

Engineers Name
Company Name
Tel No.
ID Serial No.
Comments
.....
Signature

SERVICE 4

Engineers Name
Company Name
Tel No.
ID Serial No.
Comments
.....
Signature

SERVICE 5

Engineers Name
Company Name
Tel No.
ID Serial No.
Comments
.....
Signature

SERVICE 6

Engineers Name
Company Name
Tel No.
ID Serial No.
Comments
.....
Signature

SERVICE 7

Engineers Name
Company Name
Tel No.
ID Serial No.
Comments
.....
Signature

SERVICE 8

Engineers Name
Company Name
Tel No.
ID Serial No.
Comments
.....
Signature



INSTALLATION AND USER GUIDE

ADVANCE ELECTRIC COMBINATION BOILER FOR ELECTRIC, SOLAR & RENEWABLE SOURCES

ADVANCE APPLIANCES LTD

**PLEASE RETAIN AND ENSURE SERVICE RECORDS
ARE KEPT UP TO DATE.**

SCHEMATIC

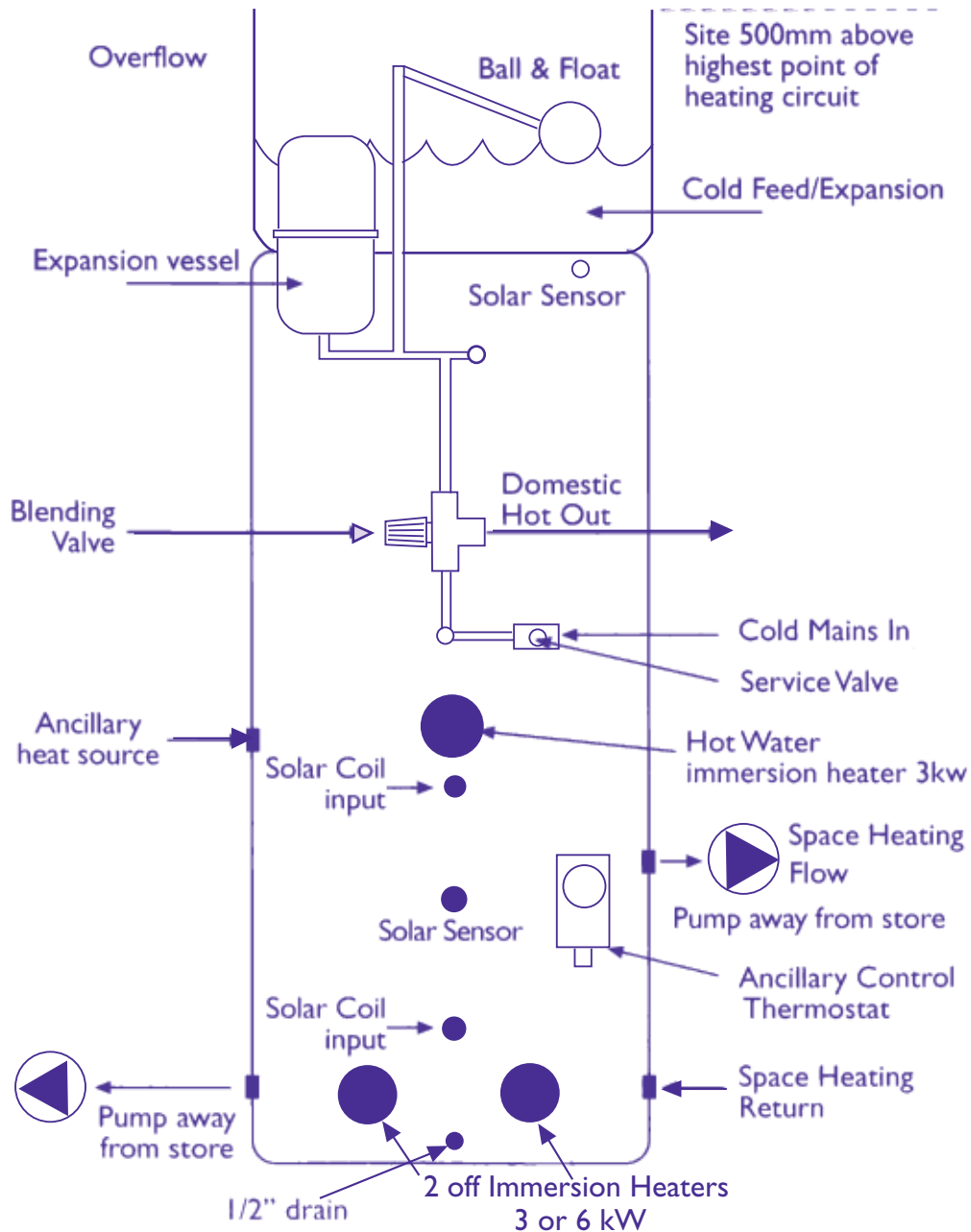

INSTALLER & COMMISSIONING ENGINEER DETAILS

Customer Details

Name

Address

Tel No.

Installer Details

Name

Address

Tel No.

DATE

REGISTRATION DETAILS
(where applicable for unvented systems)

REG No.

ID SERIAL No. etc.

Commissioning Engineer Details

Name

Address

Tel No.

DATE

REGISTRATION DETAILS
(where applicable for unvented systems)

REG No.

ID SERIAL No. etc.

Servicing Requirements

1. Check pressure reducing valve (if fitted) is 3.0 bar static and adjust if necessary.
2. Check flow rates are correct at 18 litres per minute. Clean filter in pressure reducing valve only if required.
3. Check expansion vessel change is 3.0 bar - inflate as required after decommissioning the cold supply.
4. Check ball valve float. Adjust or replace as required.

Should further assistance or clarification be required contact Advance Advice on 0121 568 8778.

Failure to carry out annual service/maintenance requirements and log proof in service/maintenance records may invalidate warranty.

Appliance Details

Manufacturer

Capacity Litres

Serial No.

General Installation

Has a check been done for joint tightness and leaks? Yes No

Has a check been done for electrical safety? Yes No

SIZE & WEIGHT

MODEL	CAPACITY	WEIGHT FULL Kg	HGT X DIA mm
ECB210	210 ltrs	270	1630 x 600
ECB250	250 ltrs	315	1880 x 600
ECB300	300 ltrs	370	2150 x 600

SPARE PARTS

EXPANSION VESSEL	AA 0001
BLENDING VALVE	AA 0002
THERMOSTAT	AA 0007
IMMERSION HEATER 3kw	AA 0005
IMMERSION HEATER 6kw	AA 0284

WIRING DIAGRAM SCHEMATIC ONLY

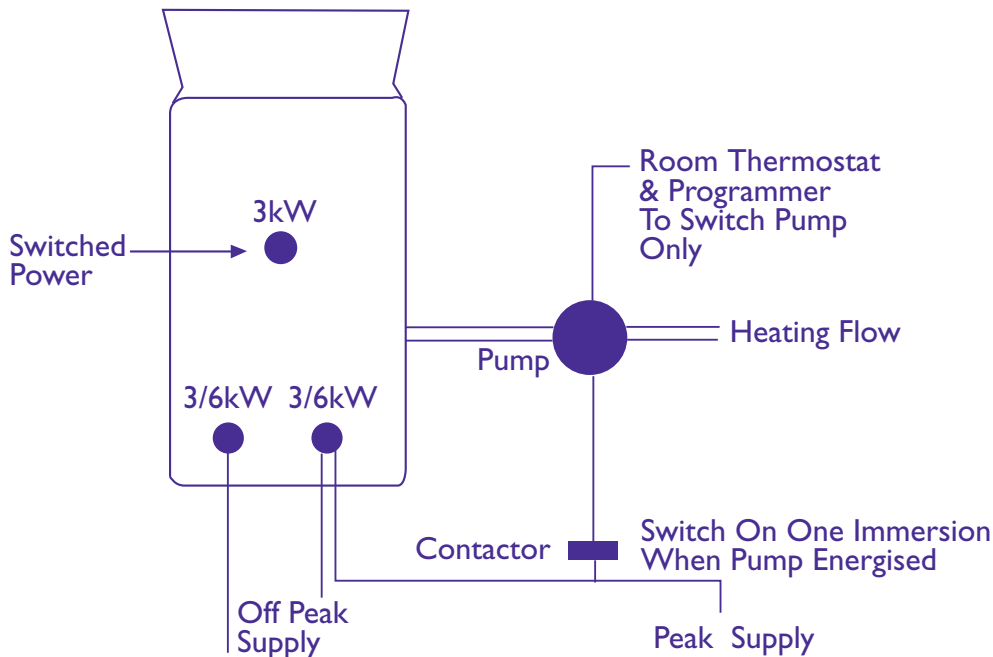

INTRODUCTION

Advance Electric Combination Boiler units for renewable and electric sources store a bank of hot water and utilise an internal, efficient heat exchanger to supply domestic hot water for showering, fast bath filling and a buffer for space heating.

OPERATION

Central Heating

The lower part of the store is used for central heating in addition to contributing energy to the domestic hot water.

The central heating is self commissioning and expansion is taken up in the cold section of the store. However, it must be sited at the top of the system, with the top of the store being 500mm above the highest point of the heating circuit.

Advance recommends that low surface temperature radiators or under floor heating systems are considered for use with the boiler. This assists the operation during the winter months when the heating output may fall below 55° C . Please note that this is not a sealed system and some under floor systems may need to be fed with a heat exchanger. Advance can supply plate heat exchangers to suit this requirement.

Water for central heating can be heated a number of ways. Although the unit is primarily an electric combination boiler, other heat sources can be utilised.

In normal operation the sensor pocket near the coil will determine if there is sufficient heat available from solar panels, and can utilise this heat source for hot water and central heating. From late spring to early autumn the unit will be almost self sufficient in this mode. In winter, the immersion heater at the bottom of the boiler can be used to heat the store to 60/75° C. When water is pumped from the store around the radiator circuit it has the benefit of providing immediate heat into the property. The immersion heater should be switched to utilise off-peak tariffs to create this store of energy, although peak tariff usage will be limited it will be required some of the time. The immersion heater must be rated to meet the needs of the property, and 6,9 and 12kw outputs are available. One of the great benefits of the boiler is that it can also be fed from additional heat sources such as wood burning appliances or heat pumps. This means that very little electrical input is required in a well designed system, allowing it to become more reliant on renewable energy.

Hot Water

The hot water is generated through an internal heat exchanger designed to maximise output. As such it is mains fed and gives excellent "power" showering without a pump and fast, safe bath filling. No feed tanks are required in the roof space.

The hot water demand, like the central heating, is largely met from solar input if fitted from late spring to early autumn. The middle immersion heater is used to boost the upper part of the tank to 75° C to ensure plentiful hot water in the winter.

Again, using other heat sources it is possible reduce the need for this immersion heater and a good wood burning appliance or heat pump would significantly reduce reliance on fossil fuel.

All hot water controls are fitted to the unit making it easy to install. Please note that these are factory fitted but may loosen in transit. A last minute check is needed on compression fittings!

Solar Input

Advance does not supply solar panels and advice is of a general nature. Always consult expert installers and manufacturers when specifying and fitting solar panels.

The general advice is to use the lower solar sensor pocket on the boiler to ensure that the temperature in the panel is higher than that in the store so that heat isn't sent to the roof.

Heat is then put into the solar coil, which will operate at pressures up to 3bar, to heat the store. The top sensor pocket will switch solar input off once a temperature of 85 to 90°C is reached. Advance would recommend 90°C as a top limit.

During the solar "season" the immersion heaters shouldn't be required and it is suggested that they are switched for low tariff top up only.

Electric Input

Noting all the operational requirements above, the immersion heaters must be wired according to the instructions supplied with each one. Higher output immersion heaters in 6kw ratings are available to match heating demand. It is imperative that these are wired through contactors as the thermostats switch at a lower rating and will burn out if not switched correctly.

Always consult the latest regulations and note that installers must be qualified to connect this equipment to the mains supply.

Ancillary Heat Input

There are two connections on the side of the boiler for use with ancillary input eg. a heat pump or a wood burning/solid fuel appliance.

Following manufacturers' instructions regarding heat sinks and so on, you can connect a solid fuel appliance to give additional energy to the store. The store makes an excellent buffer to assist efficiencies.

This addition can result in a unit that is run from renewables all year round with commensurate savings on energy bills.

If the tappings aren't used, just blank them off.

COLD SUPPLY

A minimum of 2 bar pressure through a 22mm pipe is optimum. Below this the performance may be compromised. Test the household supply by turning on mains fed taps to ensure satisfactory flow rates can be achieved.

Above 18 litres per minute is the recommended flow. It is the installer's and householder's responsibility to check these before installation.

Fit a 3 bar control valve (not supplied) if pressures are likely to be in excess of this.

NOTE: Mains pressures usually increase from late evening to early morning.

INSTALLING & PROBLEM SOLVING

Ensure the unit is installed on a flat, level surface and that it is accessible for future maintenance and that the floor will support the weight of the unit.

The weights are published in the technical data section at the back of this publication. The Advance electric combination boiler must be fitted ABOVE the top of the heating circuit.

Hot water

If hardness exceeds 200ppm, use a treatment to soften water.

Scale build-up can happen rapidly and reduce flow and efficiency.

Heating

Always flush after commissioning but DO NOT USE heavily chlorinated solutions unless you are prepared to thoroughly flush the whole heating system after heat up and cool down.

If flow is poor check incoming water supply and make sure all valves etc. are fully open.

If temperature is poor check that the store has reached 75 degrees and that the blending valve is set at the appropriate temperature.

Use inhibitor in heating systems.

The overflow must be metal or solvent weld, at least 22mm in diameter and set in continuous fall.

Continuous dripping may be caused by a high level of water in the cold section, in which case adjust the position of the ball float valve. If it is a faulty valve, replace and re-commission.

The lid can easily be removed, unscrew any holding screws and ease off. If the problem persists, shut off cold mains to check integrity of heat exchanger. If this is breached, replace the unit.

SERVICING

This should be done every 18 months to two years. Fill in the form at the back of this publication - you may need it in case of warranty issues.

Service the expansion vessel by inflating to 3 bar, check condition of ball and float valve and ensure store is inhibited with a proprietary brand of inhibitor.

WARRANTY

Warranty is for five years on the tank against failure due to manufacturing fault, and two years on components supplied and fitted to the heating manifold and thermal store.

Conditions apply, the unit must be serviced at regular intervals and a record of service must be maintained. It must be in a frost free environment and must be used for potable water only. It must be installed and used correctly in accordance with manufacturer's requirements and current best practice. Scale is not covered.

Your statutory rights are not affected by the above.